

CUSTOMER

CAN ART STD.

DIE No.

EH05825

REV. No.

1

DESCRIPTION

2" x 1" x .125" RECT. TUBE W/ RADS

CUSTOMER PART No.

QUOTE No.

06-0680-1

PROPOSAL No.

H-17311

NOTE: BREAK ALL CORNERS WITH 0.015" (.38 MM) RADIUS UNLESS OTHERWISE NOTED. STANDARD TOLERANCES TO APPLY UNLESS OTHERWISE SPECIFIED.

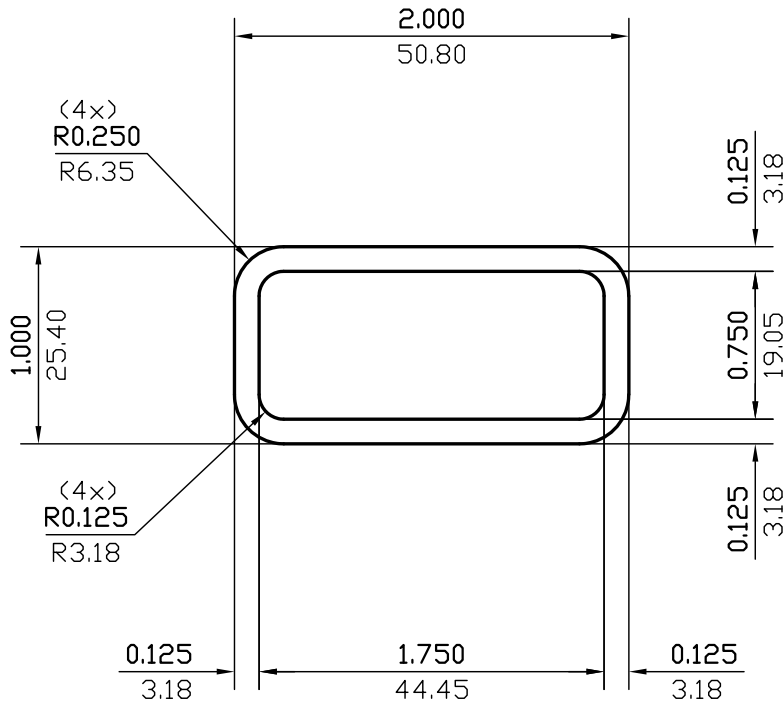

WALL THICKNESS 0.125(3.18) EXCEPT AS SHOWN

DATE	REV	DESCRIPTION	BY
03/15/23	1	REMOVED ALLOY	JASON
EST.AREA	0.647	IN. ²	EST.AREA 417.591
			MM. ²
EST.WT.	0.764	LBS/FT.	EST.WT. 1.137
			KG/M.
EST.PER.	10.356	IN.	EST.PER. 263.047
			MM.
OUT PER.	5.571	IN.	OUT PER. 141.5
			MM.
C.C.D.	2.062	IN.	C.C.D. 52.363
			MM.
FINISH	M/F		ALLOY
CKD BY	FACTOR 14	SCALE 1:1	DWN BY C.P. DATE 10/03/2006

CAN ART

ALUMINUM EXTRUSION INC.

85 PARKSHORE DRIVE
BRAMPTON, ONT L6T 5M1
TEL. NO. (905) 791-1464
FAX NO. (905) 791-9151
WEB: www.canart.com

THIS DRAWING IS NOT NECESSARILY A COPY OF YOUR ORIGINAL. PLEASE APPROVE DIMENSIONS AND TOLERANCES INDICATED. CAN ART ASSUMES NO RESPONSIBILITY EITHER TECHNICAL OR LEGAL FOR HAVING THIS SHAPE MADE. THE CUSTOMER AGREES TO FULLY PROTECT CAN ART ALUMINUM FROM CLAIMS OF OTHERS RESULTING FROM THIS SHAPE.

SIGNED: _____ DATE: _____