

CUSTOMER

**CAN ART STD.**

DIE No.

EH04000

REV. No.

**1**

DESCRIPTION

3.250 x 0.250 THK. ROUND TUBE

CUSTOMER PART No.

QUOTE No.

12-0321-1

PROPOSAL No.

H-25979

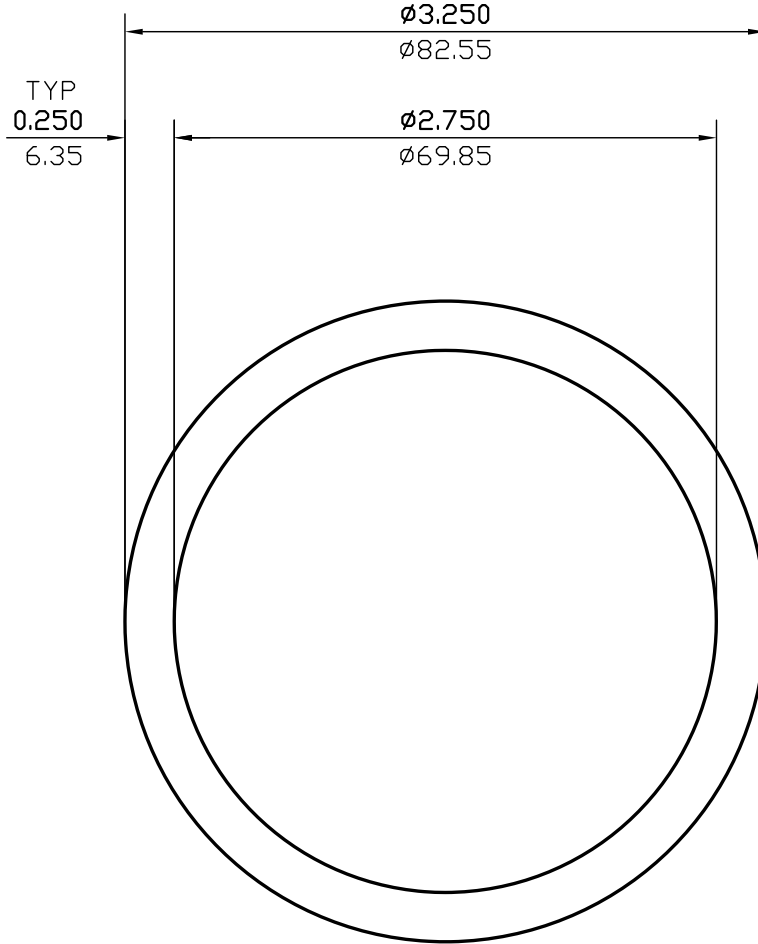

NOTE: BREAK ALL CORNERS WITH 0.015" (.38 MM) RADIUS UNLESS OTHERWISE NOTED. STANDARD TOLERANCES TO APPLY UNLESS OTHERWISE SPECIFIED.

WALL THICKNESS 0.250 (6.35) EXCEPT AS SHOWN

DATE	REV	DESCRIPTION	BY
03/10/23	1	REMOVED ALLOY	JASON

EST.AREA	2.356	IN. <sup>2</sup>	EST.AREA	1520.134	MM. <sup>2</sup>
EST.WT.	2.780	LBS/FT.	EST.WT.	4.138	KG/M.
EST.PER.	18.850	IN.	EST.PER.	478.779	MM.
OUT PER.	10.210	IN.	OUT PER.	259.3	MM.
C.C.D.	3.250	IN.	C.C.D.	82.550	MM.
FINISH	M/F		ALLOY		
CKD BY	FACTOR 7	SCALE 1:1	DWN BY P.M.	DATE 03/15/2012	

**CAN ART**

ALUMINUM EXTRUSION INC.

85 PARKSHORE DRIVE  
BRAMPTON, ONT L6T 5M1  
TEL. NO. (905) 791-1464  
FAX NO. (905) 791-9151  
WEB: www.canart.com

THIS DRAWING IS NOT NECESSARILY A COPY OF YOUR ORIGINAL. PLEASE APPROVE DIMENSIONS AND TOLERANCES INDICATED. CAN ART ASSUMES NO RESPONSIBILITY EITHER TECHNICAL OR LEGAL FOR HAVING THIS SHAPE MADE. THE CUSTOMER AGREES TO FULLY PROTECT CAN ART ALUMINUM FROM CLAIMS OF OTHERS RESULTING FROM THIS SHAPE.

SIGNED: \_\_\_\_\_ DATE: \_\_\_\_\_