

CUSTOMER PART No.	CUSTOMER <b>CAN ART STD.</b>	DIE No. <b>EH05589</b>
DESCRIPTION .875" DIA. x .120"THK. ROUND TUBE	PROPOSAL No. H-7217	

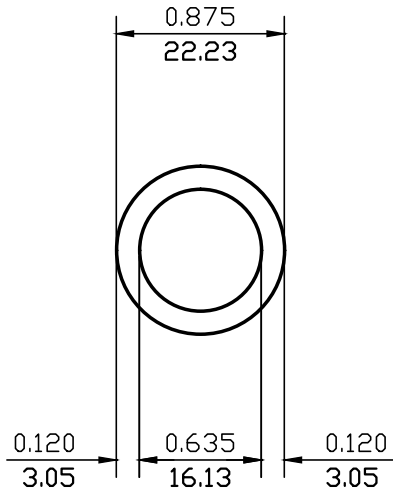

NOTE: BREAK ALL CORNERS WITH 0.015" (.38 MM) RADIUS UNLESS OTHERWISE NOTED. STANDARD TOLERANCES TO APPLY UNLESS OTHERWISE SPECIFIED.

WALL THICKNESS 0.120 (3.05) EXCEPT AS SHOWN

DATE	REV	DESCRIPTION	BY
EST.AREA	0.285	IN. <sup>2</sup>	EST.AREA 183.632
EST.WT.	0.342	LBS/FT.	EST.WT. 0.508
EST.PER.	4.744	IN.	EST.PER. 120.493
OUT PER.	2.749	IN.	OUT PER. 69.8
C.C.D.	0.875	IN.	C.C.D. 22.225
FACTOR 14	FINISH M/F	ALLOY & TEMP.	
CKD BY	SCALE 1:1	DWN BY C.P.	DATE 12/24/97

# CAN ART

85 PARKSHORE DRIVE  
BRAMPTON, ONT L6T 5M1  
TEL. NO. (905) 791-1464  
FAX NO. (905) 791-9151  
E-MAIL: canart@canart.com

ALUMINUM EXTRUSION INC.

THIS DRAWING IS NOT NECESSARILY A COPY OF YOUR ORIGINAL. PLEASE APPROVE DIMENSIONS AND TOLERANCES INDICATED. CAN ART ASSUMES NO RESPONSIBILITY EITHER TECHNICAL OR LEGAL FOR HAVING THIS SHAPE MADE. THE CUSTOMER AGREES TO FULLY PROTECT CAN ART ALUMINUM FROM CLAIMS OF OTHERS RESULTING FROM THIS SHAPE.

SIGNED: \_\_\_\_\_ DATE: \_\_\_\_\_