

NOTE: BREAK ALL CORNERS WITH 0.015" (.38 MM) RADIUS UNLESS OTHERWISE NOTED. STANDARD TOLERANCES TO APPLY UNLESS OTHERWISE SPECIFIED.

CUSTOMER		CAN ART STD.		DIE No.	ES05994	REV. No.	0
DESCRIPTION			CUSTOMER PART No.	QUOTE No.	PROPOSAL No.		
1.250 x 0.750 x 0.125 ANGLE				11-1101-1	S-25273		

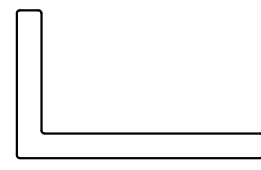
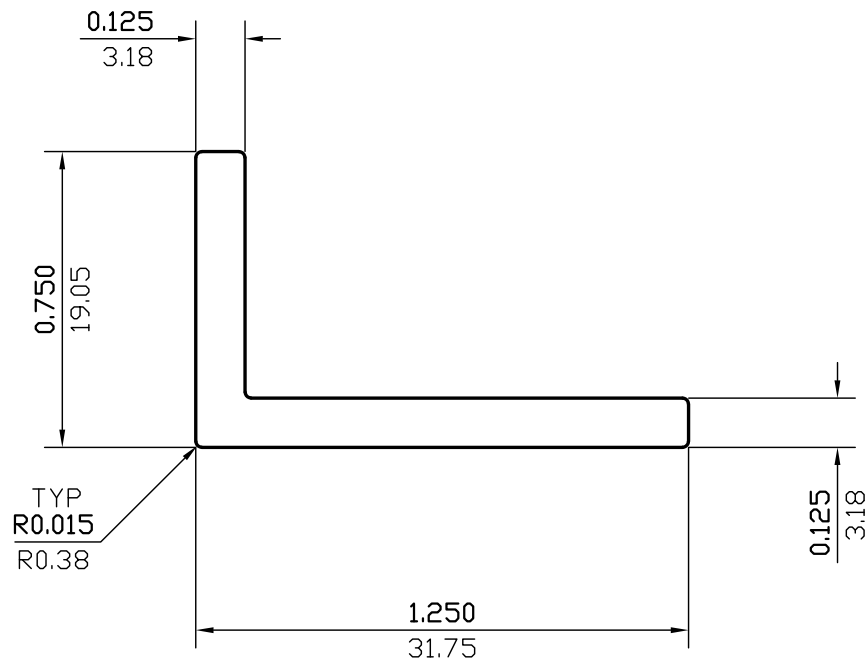

ACTUAL SIZE

WALL THICKNESS 0.125 (3.18) EXCEPT AS SHOWN

DATE	REV	DESCRIPTION	BY
03/20/23	1	REMOVED ALLOY	JASON
EST.AREA	0.234	IN. ²	EST.AREA 151.086
			MM. ²
EST.WT.	0.276	LBS/FT.	EST.WT. 0.411
			KG/M.
EST.PER.	3.961	IN.	EST.PER. 100.619
			MM.
OUT PER.		IN.	OUT PER.
			MM.
C.C.D.	1.446	IN.	C.C.D. 36.720
			MM.
FINISH	M/F		ALLOY
CKD BY	FACTOR 14	SCALE 2:1	DWN BY P.M. DATE 11/25/2011

CAN ART

85 PARKSHORE DRIVE
BRAMPTON, ONT L6T 5M1
TEL. NO. (905) 791-1464
FAX NO. (905) 791-9151
WEB: www.canart.com

ALUMINUM EXTRUSION INC.

THIS DRAWING IS NOT NECESSARILY A COPY OF YOUR ORIGINAL. PLEASE APPROVE DIMENSIONS AND TOLERANCES INDICATED. CAN ART ASSUMES NO RESPONSIBILITY EITHER TECHNICAL OR LEGAL FOR HAVING THIS SHAPE MADE. THE CUSTOMER AGREES TO FULLY PROTECT CAN ART ALUMINUM FROM CLAIMS OF OTHERS RESULTING FROM THIS SHAPE.

SIGNED: _____ DATE: _____