

NOTE: BREAK ALL CORNERS WITH 0.015" (.38 MM) RADIUS UNLESS OTHERWISE NOTED. STANDARD TOLERANCES TO APPLY UNLESS OTHERWISE SPECIFIED.

CUSTOMER	CAN ART STD.	DIE No. EH62680	REV. No. 2
DESCRIPTION 4.000 x 0.375 THK. SQ. TUBE	CUSTOMER PART No.	QUOTE No. 10-0422-1	PROPOSAL No. H-22595

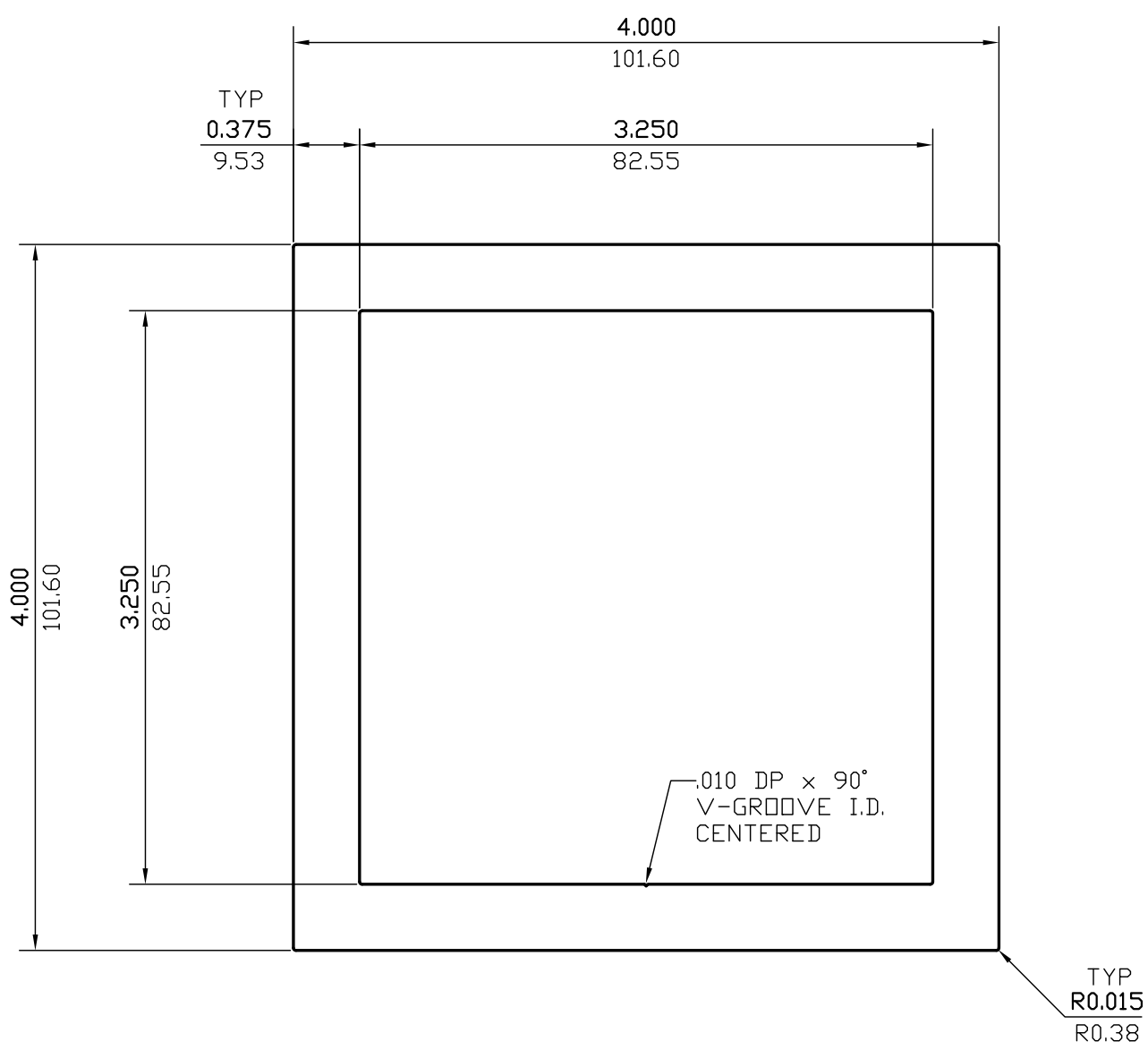

WALL THICKNESS 0.375 (9.53) EXCEPT AS SHOWN

DATE	REV	DESCRIPTION	BY		
03/13/23	2	REMOVED ALLOY	JASON		
10/10/2013	1	CHANGED CUSTOMER NAME	J.T.		
EST.AREA	5.437	IN. ²	EST.AREA	3508.021	MM. ²
EST.WT.	6.525	LBS/FT.	EST.WT.	9.710	KG/M.
EST.PER.	28.957	IN.	EST.PER.	735.502	MM.
OUT PER.	15.974	IN.	OUT PER.	405.7	MM.
C.C.D.	5.644	IN.	C.C.D.	143.368	MM.
FINISH	M/F		ALLOY		
CKD BY	FACTOR 4	SCALE 1:1	DWN BY P.M.	DATE 04/01/2010	

CAN ART

85 PARKSHORE DRIVE
BRAMPTON, ONT L6T 5M1
TEL. NO. (905) 791-1464
FAX NO. (905) 791-9151
WEB: www.canart.com

ALUMINUM EXTRUSION INC.

THIS DRAWING IS NOT NECESSARILY A COPY OF YOUR ORIGINAL. PLEASE APPROVE DIMENSIONS AND TOLERANCES INDICATED. CAN ART ASSUMES NO RESPONSIBILITY EITHER TECHNICAL OR LEGAL FOR HAVING THIS SHAPE MADE. THE CUSTOMER AGREES TO FULLY PROTECT CAN ART ALUMINUM FROM CLAIMS OF OTHERS RESULTING FROM THIS SHAPE.

SIGNED: _____ DATE: _____