

CUSTOMER CAN ART STD.		DIE No. EH11533	REV. No. 1
DESCRIPTION 3.000 x 1.750 x 0.188 RECT. TUBE	CUSTOMER PART No.	QUOTE No. 11-0547-1-R-1	PROPOSAL No. H-10468

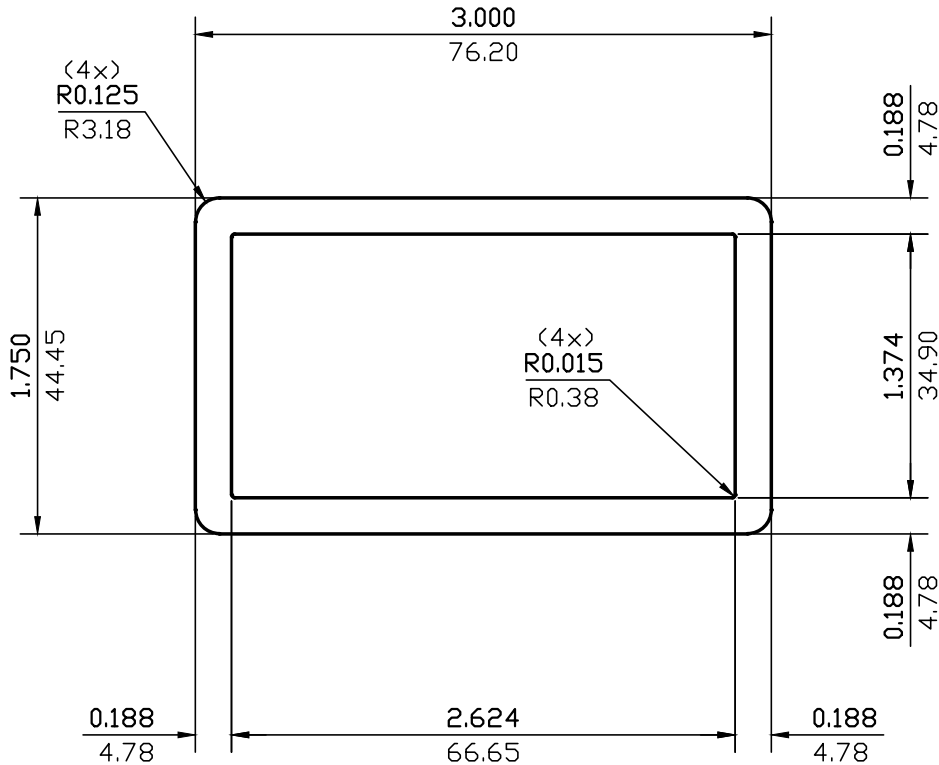

NOTE: BREAK ALL CORNERS WITH 0.015" (.38 MM) RADIUS UNLESS OTHERWISE NOTED. STANDARD TOLERANCES TO APPLY UNLESS OTHERWISE SPECIFIED.

WALL THICKNESS **0.188 (4.78)** EXCEPT AS SHOWN

DATE	REV	DESCRIPTION	BY
EST.AREA	1.631	IN. ²	EST.AREA 1052.525 MM. ²
EST.WT.	1.925	LBS./FT.	EST.WT. 2.865 KG/M.
EST.PER.	17.256	IN.	EST.PER. 438.293 MM.
OUT PER.	9.285	IN.	OUT PER. 235.8 MM.
C.C.D.	3.389	IN.	C.C.D. 86.081 MM.
FINISH	M/F		ALLOY
CKD BY	FACTOR 9	SCALE 1:1	DWN BY C.P. DATE 11/23/2000

CAN ART

85 PARKSHORE DRIVE
BRAMPTON, ONT L6T 5M1
TEL. NO. (905) 791-1464
FAX NO. (905) 791-9151
WEB: www.canart.com

ALUMINUM EXTRUSION INC.

THIS DRAWING IS NOT NECESSARILY A COPY OF YOUR ORIGINAL. PLEASE APPROVE DIMENSIONS AND TOLERANCES INDICATED. CAN ART ASSUMES NO RESPONSIBILITY EITHER TECHNICAL OR LEGAL FOR HAVING THIS SHAPE MADE. THE CUSTOMER AGREES TO FULLY PROTECT CAN ART ALUMINUM FROM CLAIMS OF OTHERS RESULTING FROM THIS SHAPE.

SIGNED: _____ DATE: _____