

CUSTOMER

CAN ART STD.

DIE No.

EH05860

REV. No.

1

DESCRIPTION

4" x 4" x .250" SQ. TUBE W/ RADS

CUSTOMER PART No.

QUOTE No.

L07-0480-2

PROPOSAL No.

H-55697

NOTE: BREAK ALL CORNERS WITH 0.015" (.38 MM) RADIUS UNLESS OTHERWISE NOTED. STANDARD TOLERANCES TO APPLY UNLESS OTHERWISE SPECIFIED.

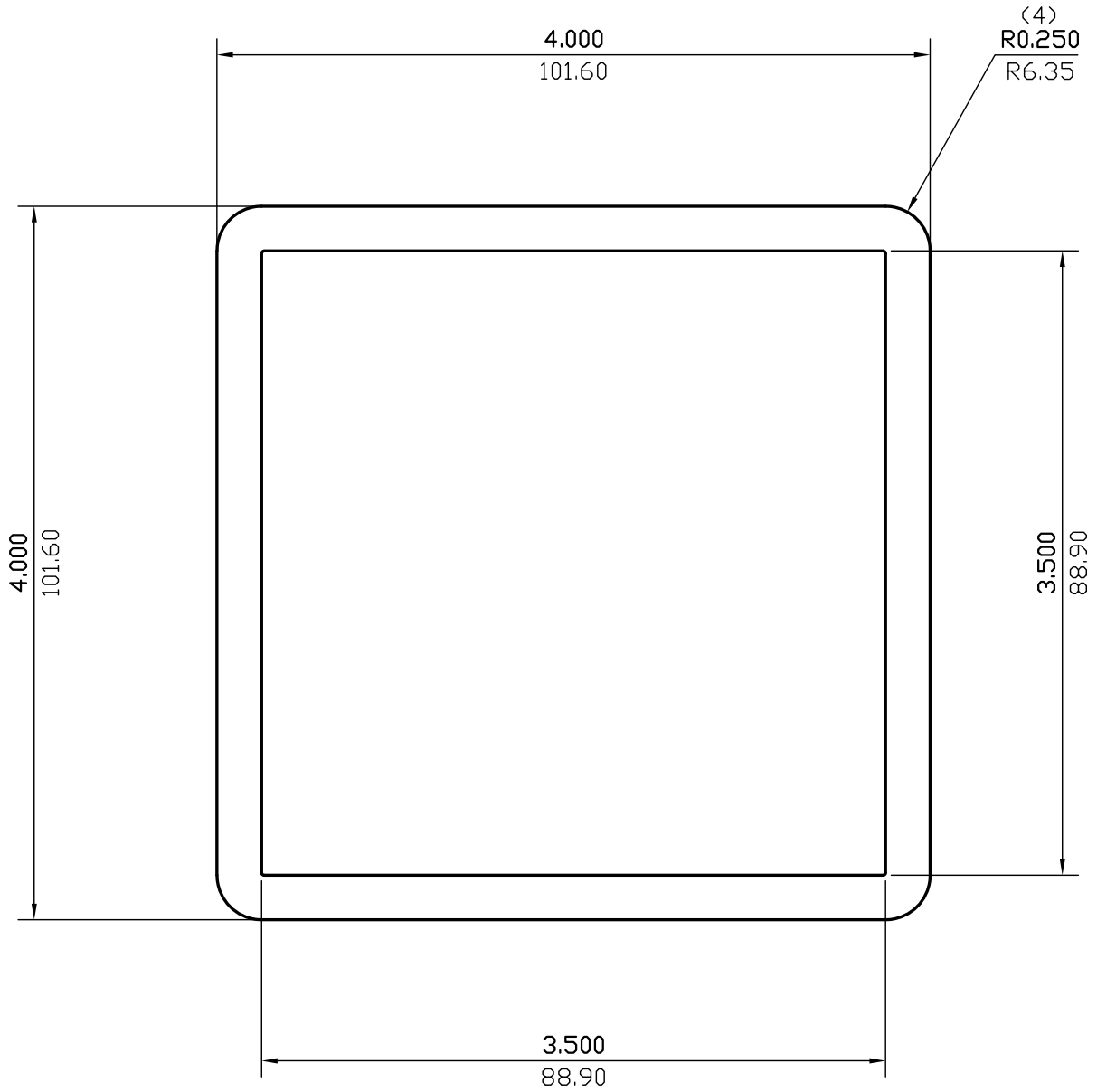

WALL THICKNESS 0.250 (6.35) EXCEPT AS SHOWN

DATE	REV	DESCRIPTION	BY					
03/14/23	1	REMOVED ALLOY	JASON					
EST.AREA	3.697	IN. ²	EST.AREA	2384.880	MM. ²			
EST.WT.	4.436	LBS/FT.	EST.WT.	6.601	KG/M.			
EST.PER.	29.545	IN.	EST.PER.	750.444	MM.			
OUT PER.	15.571	IN.	OUT PER.	395.5	MM.			
C.C.D.	5.450	IN.	C.C.D.	138.424	MM.			
FINISH	M/F		ALLOY					
CKD BY	FACTOR	7	SCALE	1:1	DWN BY	J.T.	DATE	02/25/2008

CAN ART

ALUMINUM EXTRUSION INC.

428 JUTRAS DRIVE S.
WINDSOR, ON N8N 5C5
TEL. NO. (519) 727-4399
FAX NO. (519) 727-6434
WEB: www.canart.com

THIS DRAWING IS NOT NECESSARILY A COPY OF YOUR ORIGINAL. PLEASE APPROVE DIMENSIONS AND TOLERANCES INDICATED. CAN ART ASSUMES NO RESPONSIBILITY EITHER TECHNICAL OR LEGAL FOR HAVING THIS SHAPE MADE. THE CUSTOMER AGREES TO FULLY PROTECT CAN ART ALUMINUM FROM CLAIMS OF OTHERS RESULTING FROM THIS SHAPE.

SIGNED: _____ DATE: _____