

CUSTOMER

CAN ART STD.

DIE No.

EH05846

REV. No.

1

DESCRIPTION

3.000 x .250 SQUARE TUBE

CUSTOMER PART No.

QUOTE No.

L07-0510-5

PROPOSAL No.

H-55768

NOTE: BREAK ALL CORNERS WITH 0.015" (.38 MM) RADIUS UNLESS OTHERWISE NOTED. STANDARD TOLERANCES TO APPLY UNLESS OTHERWISE SPECIFIED.

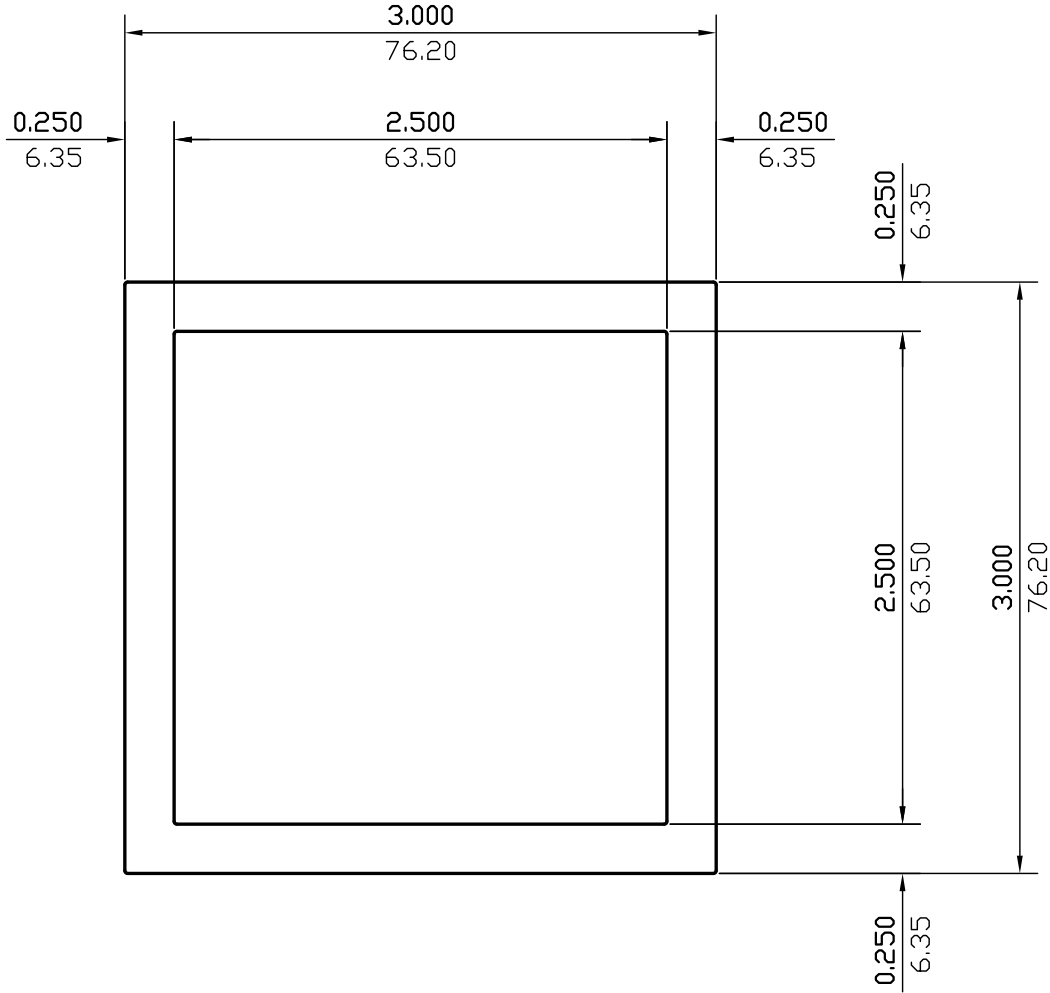

WALL THICKNESS 0.250(6.35) EXCEPT AS SHOWN

DATE	REV	DESCRIPTION	BY
03/13/23	1	REMOVED ALLOY	JASON
EST.AREA	2.750	IN. ²	EST.AREA 1774.204
			MM. ²
EST.WT.	3.300	LBS/FT.	EST.WT. 4.911
			KG/M.
EST.PER.	21.948	IN.	EST.PER. 557.492
			MM.
OUT PER.	11.974	IN.	OUT PER. 304.1
			MM.
C.C.D.	4.221	IN.	C.C.D. 107.224
			MM.
FINISH	M/F		ALLOY
CKD BY	FACTOR 7	SCALE 1:1	DWN BY L.G. DATE 12/12/2007

CAN ART

ALUMINUM EXTRUSION INC.

428 JUTRAS DRIVE S.
WINDSOR, ON N8N 5C5
TEL. NO. (519) 727-4399
FAX NO. (519) 727-6434
WEB: www.canart.com

THIS DRAWING IS NOT NECESSARILY A COPY OF YOUR ORIGINAL. PLEASE APPROVE DIMENSIONS AND TOLERANCES INDICATED. CAN ART ASSUMES NO RESPONSIBILITY EITHER TECHNICAL OR LEGAL FOR HAVING THIS SHAPE MADE. THE CUSTOMER AGREES TO FULLY PROTECT CAN ART ALUMINUM FROM CLAIMS OF OTHERS RESULTING FROM THIS SHAPE.

SIGNED: _____ DATE: _____