

CUSTOMER

CAN ART STD.

DIE No.

EH05820

REV. No.

1

DESCRIPTION

2" x 2" x .125" SQ. TUBE W/ RADS

CUSTOMER PART No.

QUOTE No.

06-0268-3

PROPOSAL No.

H-16809

NOTE: BREAK ALL CORNERS WITH 0.015" (.38 MM) RADIUS UNLESS OTHERWISE NOTED. STANDARD TOLERANCES TO APPLY UNLESS OTHERWISE SPECIFIED.

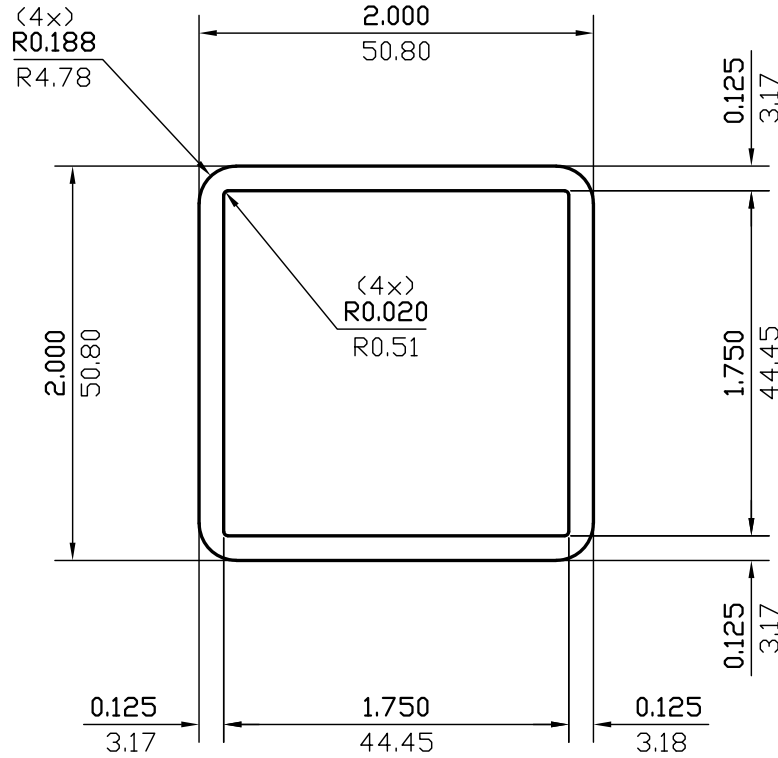

WALL THICKNESS **0.125(3.18)** EXCEPT AS SHOWN

DATE	REV	DESCRIPTION	BY		
03/13/23	1	REMOVED ALLOY	JASON		
EST.AREA	0.908	IN. ²	EST.AREA	585.490	MM. ²
EST.WT.	1.071	LBS/FT.	EST.WT.	1.594	KG/M.
EST.PER.	14.643	IN.	EST.PER.	371.930	MM.
OUT PER.	7.677	IN.	OUT PER.	195.0	MM.
C.C.D.	2.673	IN.	C.C.D.	67.886	MM.
FINISH	M/F		ALLOY		
CKD BY	FACTOR 14	SCALE 1:1	DWN BY C.P.	DATE 04/18/2006	

CAN ART

ALUMINUM EXTRUSION INC.

85 PARKSHORE DRIVE
BRAMPTON, ONT L6T 5M1
TEL. NO. (905) 791-1464
FAX NO. (905) 791-9151
WEB: www.canart.com

THIS DRAWING IS NOT NECESSARILY A COPY OF YOUR ORIGINAL. PLEASE APPROVE DIMENSIONS AND TOLERANCES INDICATED. CAN ART ASSUMES NO RESPONSIBILITY EITHER TECHNICAL OR LEGAL FOR HAVING THIS SHAPE MADE. THE CUSTOMER AGREES TO FULLY PROTECT CAN ART ALUMINUM FROM CLAIMS OF OTHERS RESULTING FROM THIS SHAPE.

SIGNED: _____ DATE: _____