

NOTE: BREAK ALL CORNERS WITH 0.015" (.38 MM) RADIUS UNLESS OTHERWISE NOTED. STANDARD TOLERANCES TO APPLY UNLESS OTHERWISE SPECIFIED.

CUSTOMER PART No.	<b>CAN ART STD.</b>	DIE No. <b>EH05717</b>
DESCRIPTION	1.000 x 1.000 x 0.125	PROPOSAL No. <b>H-50288</b>

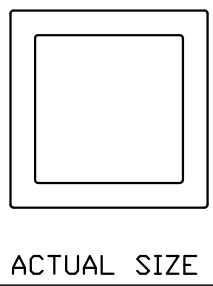
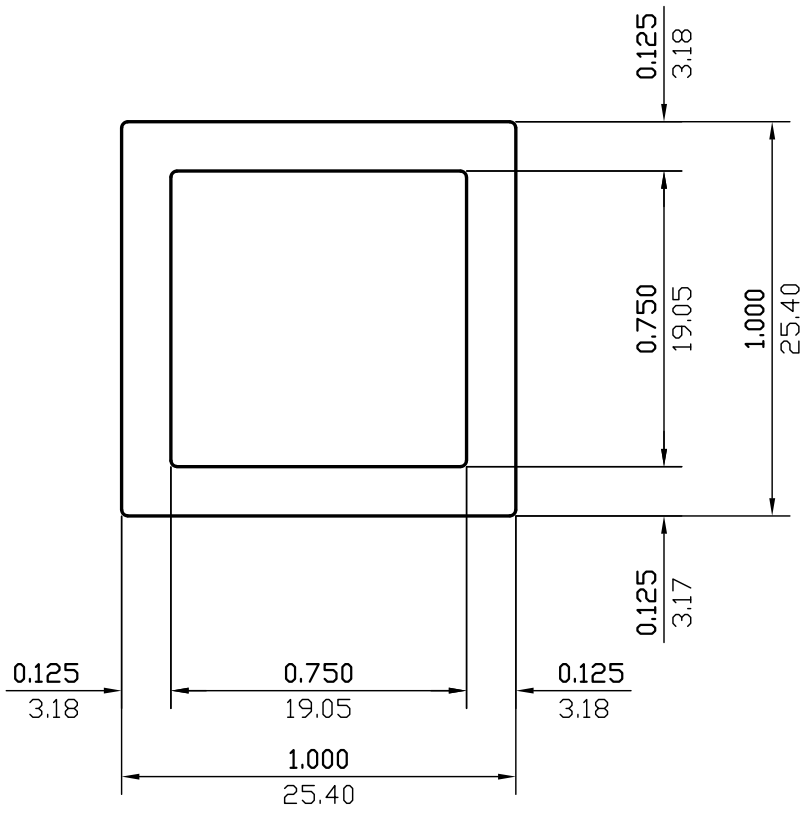

WALL THICKNESS **0.125(3.18)** EXCEPT AS SHOWN

DATE	REV	DESCRIPTION	BY
03/13/23	1	REMOVED ALLOY	JASDN
EST.AREA	0.437	IN. <sup>2</sup>	EST.AREA 282.260
			MM. <sup>2</sup>
EST.WT.	0.525	LBS./FT.	EST.WT. 0.781
			KG/M.
EST.PER.	6.948	IN.	EST.PER. 176.492
			MM.
OUT PER.	3.974	IN.	OUT PER. 100.9
			MM.
C.C.D.	1.402	IN.	C.C.D. 35.605
			MM.
FACTOR	13	FINISH	M/F
		ALLOY & TEMP.	
CKD BY	SCALE	2:1	DWN BY L.L. DATE 11/05/2001

# CAN ART

ALUMINUM EXTRUSION INC.

428 JUTRAS DRIVE S.  
WINDSOR, ONT. L6T 5M1  
TEL. NO. (519) 727-4399  
FAX NO. (519) 727-6434  
E-MAIL: canart@canart.com

THIS DRAWING IS NOT NECESSARILY A COPY OF YOUR ORIGINAL. PLEASE APPROVE DIMENSIONS AND TOLERANCES INDICATED. CAN ART ASSUMES NO RESPONSIBILITY EITHER TECHNICAL OR LEGAL FOR HAVING THIS SHAPE MADE. THE CUSTOMER AGREES TO FULLY PROTECT CAN ART ALUMINUM FROM CLAIMS OF OTHERS RESULTING FROM THIS SHAPE.

SIGNED: \_\_\_\_\_ DATE: \_\_\_\_\_