

CUSTOMER PART No.	CUSTOMER CAN ART STD.	DIE No. EH05569
DESCRIPTION	2.562" x 2.062" x 0.125" THK. RECT. TUBE	
		PROPOSAL No. H-6583

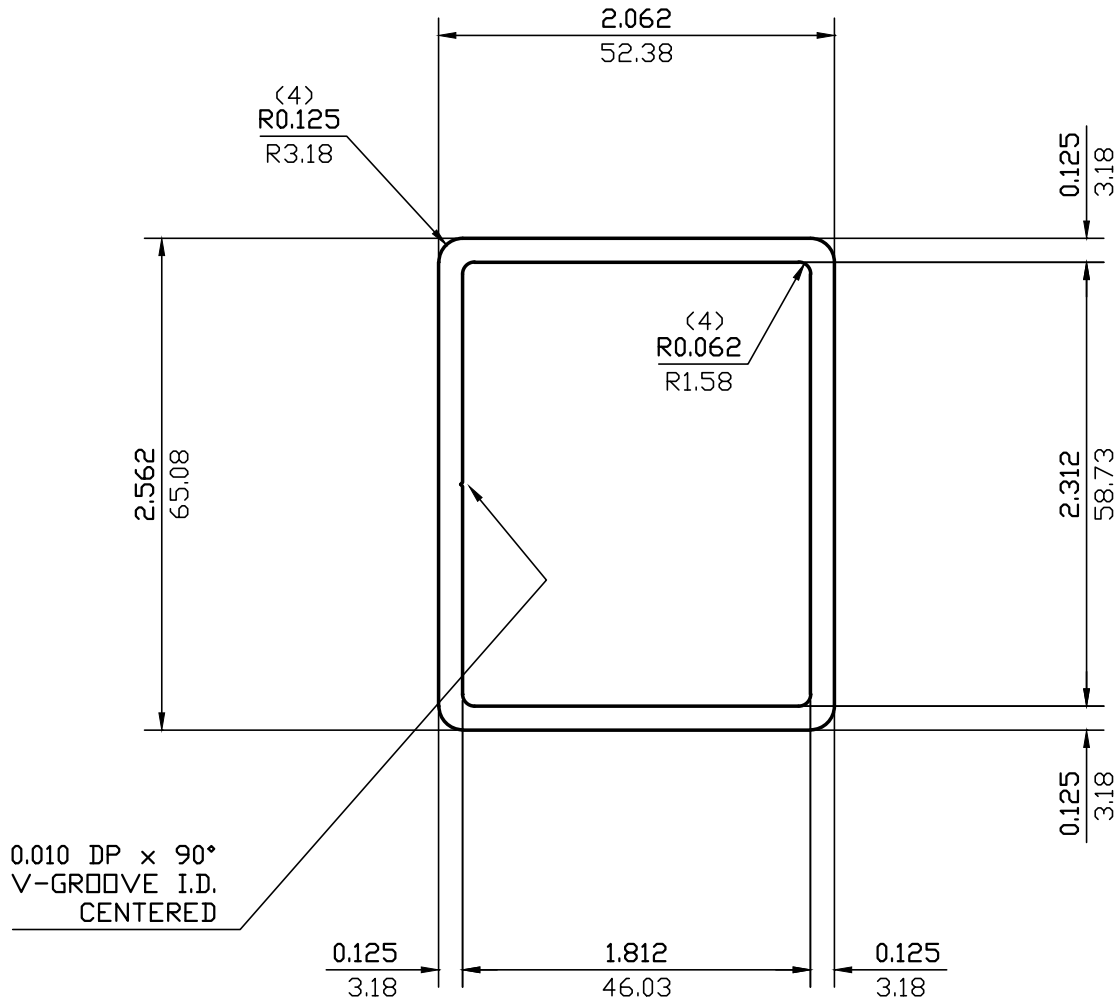

NOTE: BREAK ALL CORNERS WITH 0.015" (.38 MM) RADIUS UNLESS OTHERWISE NOTED. STANDARD TOLERANCES TO APPLY UNLESS OTHERWISE SPECIFIED.

WALL THICKNESS 0.125 (3.18) EXCEPT AS SHOWN

DATE	REV	DESCRIPTION	BY
EST.AREA	1.083	IN. ²	EST.AREA 699
EST.WT.	1.300	LBS/FT.	EST.WT. 1.935
EST.PER.	17.183	IN.	EST.PER. 436.5
OUT PER.	9.033	IN.	OUT PER. 229.4
C.C.D.	3.189	IN.	C.C.D. 81
FACTOR	13	FINISH M/F	ALLOY & TEMP. 6063
CKD BY	SCALE 1:1	DWN BY C.P.	DATE 06/13/97

CAN ART

ALUMINUM EXTRUSION INC.

85 PARKSHORE DRIVE
BRAMPTON, ONT L6T 5M1
TEL. NO. (905) 791-1464
FAX NO. (905) 791-9151
E-MAIL: canart@canart.com

THIS DRAWING IS NOT NECESSARILY A COPY OF YOUR ORIGINAL. PLEASE APPROVE DIMENSIONS AND TOLERANCES INDICATED. CAN ART ASSUMES NO RESPONSIBILITY EITHER TECHNICAL OR LEGAL FOR HAVING THIS SHAPE MADE. THE CUSTOMER AGREES TO FULLY PROTECT CAN ART ALUMINUM FROM CLAIMS OF OTHERS RESULTING FROM THIS SHAPE.

SIGNED: _____ DATE: _____