

CUSTOMER PART No.

CUSTOMER

CAN ART STD.

DIE No.

EH05410

DESCRIPTION

3/4" x 3/4" x .062" THK. SQ. TUBE

PROPOSAL No.

H-2704

NOTE: BREAK ALL CORNERS WITH 0.015" (.38 MM) RADIUS UNLESS OTHERWISE NOTED. STANDARD TOLERANCES TO APPLY UNLESS OTHERWISE SPECIFIED.

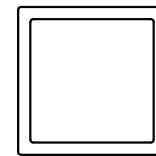
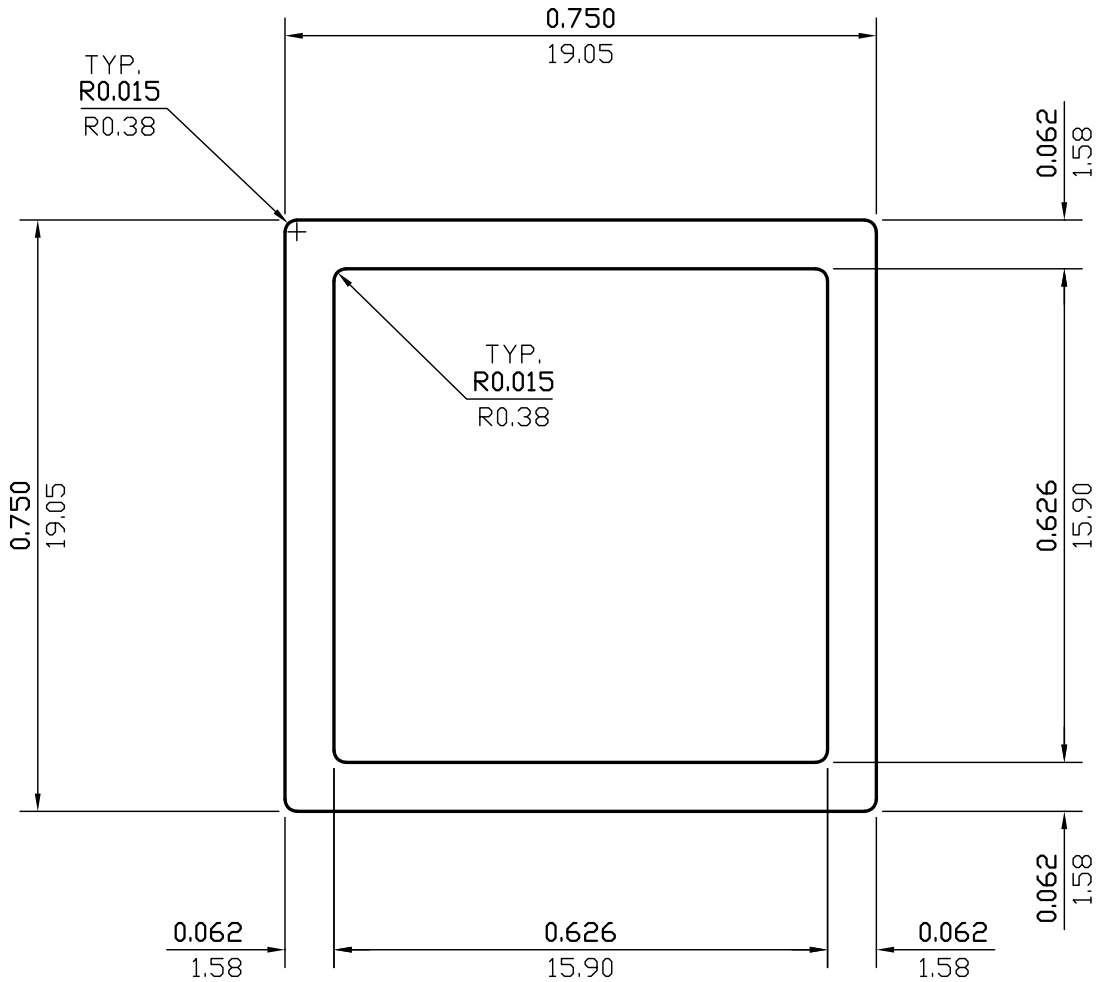

ACTUAL SIZE

WALL THICKNESS 0.062(1.58) EXCEPT AS SHOWN

DATE	REV	DESCRIPTION	BY
03/13/23	2	REMOVED ALLOY	JASON
08/05/99	1	REDRAWN	P.M.
EST.AREA	0.171	IN. ²	EST.AREA 110.081
			MM. ²
EST.WT.	0.201	LBS/FT.	EST.WT. 0.300
			KG/M.
EST.PER.	5.504	IN.	EST.PER. 139.802
			MM.
OUT PER.	3.000	IN.	OUT PER. 76.2
			MM.
C.C.D.	1.061	IN.	C.C.D. 26.941
			MM.
FACTOR	27	FINISH	M/F
		ALLOY & TEMP.	
CKD BY	SCALE 4:1	DWN BY	C.P. DATE 09/28/2000

CAN ART

ALUMINUM EXTRUSION INC.

85 PARKSHORE DRIVE
BRAMPTON, ONT L6T 5M1
TEL. NO. (905) 791-1464
FAX NO. (905) 791-9151
E-MAIL: canart@canart.com

THIS DRAWING IS NOT NECESSARILY A COPY OF YOUR ORIGINAL. PLEASE APPROVE DIMENSIONS AND TOLERANCES INDICATED. CAN ART ASSUMES NO RESPONSIBILITY EITHER TECHNICAL OR LEGAL FOR HAVING THIS SHAPE MADE. THE CUSTOMER AGREES TO FULLY PROTECT CAN ART ALUMINUM FROM CLAIMS OF OTHERS RESULTING FROM THIS SHAPE.

SIGNED: _____ DATE: _____