

CUSTOMER PART No.

CUSTOMER

**CAN ART STD.**

DIE No.

EH05179

DESCRIPTION

7/8" x 7/8" x 0.065" THK. SQ. TUBE

PROPOSAL No.

H-963

NOTE: BREAK ALL CORNERS WITH 0.015" (.38 MM) RADIUS UNLESS OTHERWISE NOTED. STANDARD TOLERANCES TO APPLY UNLESS OTHERWISE SPECIFIED.

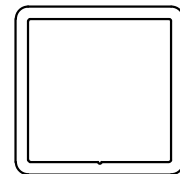
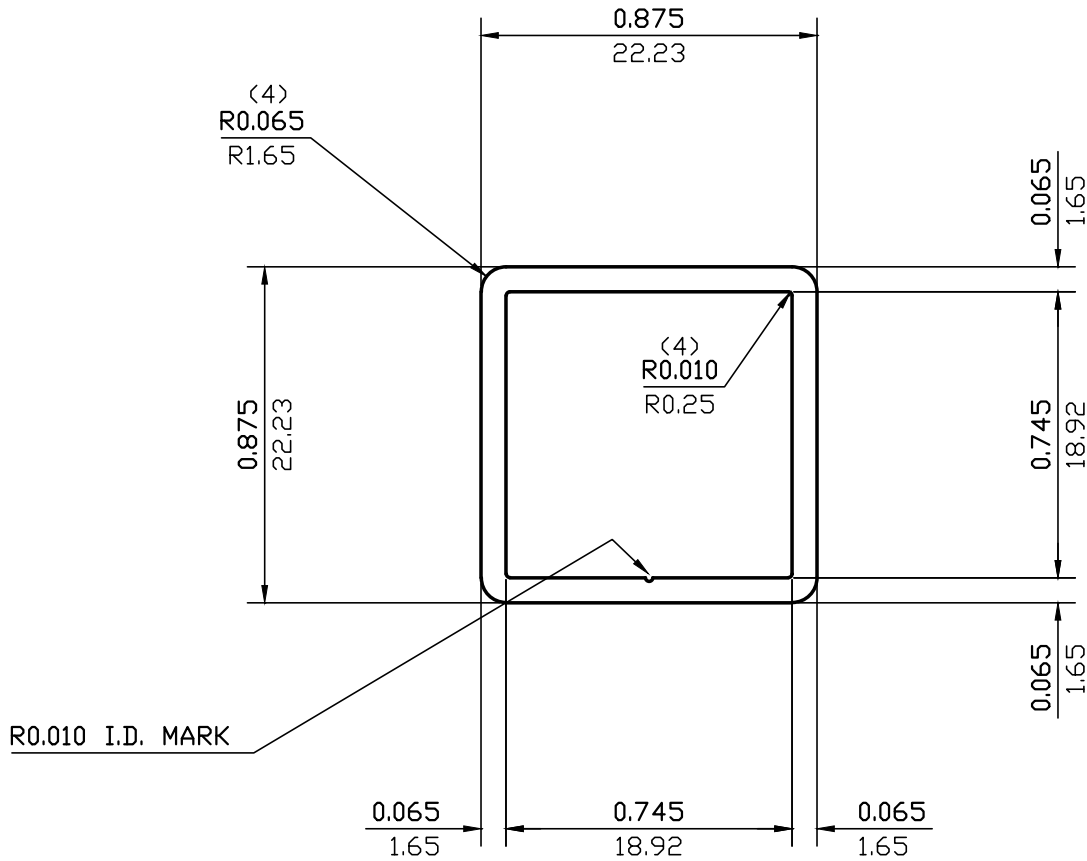

ACTUAL SIZE

WALL THICKNESS 0.065 (1.65) EXCEPT AS SHOWN

DATE	REV	DESCRIPTION	BY
EST.AREA	0.207	IN. <sup>2</sup>	EST.AREA 133
EST.WT.	0.244	LBS/FT.	EST.WT. 0.363
EST.PER.	6.363	IN.	EST.PER. 161.6
OUT PER.	3.388	IN.	OUT PER. 86.1
C.C.D.	1.184	IN.	C.C.D. 30
FACTOR	26	FINISH	M/F
		ALLOY & TEMP.	6061
CKD BY	SCALE	2:1	DWN BY G.M. DATE 11/23/88

**CAN ART**

ALUMINUM EXTRUSION INC.

85 PARKSHORE DRIVE  
BRAMPTON, ONT L6T 5M1  
TEL. NO. (905) 791-1464  
FAX NO. (905) 791-9151  
E-MAIL: canart@canart.com

THIS DRAWING IS NOT NECESSARILY A COPY OF YOUR ORIGINAL. PLEASE APPROVE DIMENSIONS AND TOLERANCES INDICATED. CAN ART ASSUMES NO RESPONSIBILITY EITHER TECHNICAL OR LEGAL FOR HAVING THIS SHAPE MADE. THE CUSTOMER AGREES TO FULLY PROTECT CAN ART ALUMINUM FROM CLAIMS OF OTHERS RESULTING FROM THIS SHAPE.

SIGNED: \_\_\_\_\_ DATE: \_\_\_\_\_